

EC²



space saver

LVQ 3V

GATED SQUARE WAVE GENERATOR

- T²L LV CMOS input and outputs
- Output wavetrain can be started in sync with random events
- 8-pin Space Saver package
- Leads - thru-hole, J, Gull Wing or Tucked
- Available in frequencies from 2 MHz to 80 MHz
- Output frequencies controlled to within $\pm 2\%$
- 12mA output drive capability

design notes

The LVQ "Space Saver Series" Gated Square Wave Generator modules developed by Engineered Components Company have been designed to provide a square wave output at frequencies from 2 MHz to 80 MHz. These generators are both keyable and synchronizable, producing a continuous output train as long as a zero (low) is maintained at the enable input. As long as the enable input is a "1" (high), OUT₁ will be a constant "1" (high) and OUT₂ will be a constant "0" (low). Whenever the enable input goes low, OUT₂ goes high immediately. OUT₁ and OUT₂ go low together after a one-half cycle delay and, thereafter run in phase. When enable input returns to high, OUT₂ is forced low immediately and OUT₁ is forced high one-half cycle later. (Note: The output buffers will add one propagation delay to all times).

These Gated Square Wave Generator modules are of hybrid construction utilizing the proven technologies of active integrated

circuitry and of passive networks utilizing capacitive, inductive and resistive elements. The MTBF on these modules, when calculated per MIL-HDBK-217 for a 50°C ground fixed environment, is in excess of 4 million hours.

The SSGSWG-LVQ is offered in 28 different frequencies from 2 MHz to 80 MHz. Output frequencies are controlled to within $\pm 2\%$ and have a temperature coefficient of less than ± 600 ppm/°C over the operating temperature range of -40 to +85°C.

These LVQ "Space Saver Series" modules are packaged in an 8-pin housing, molded of flame-proof Diallyl Phthalate per MIL-M-14, Type SDG-F, and are fully encapsulated in epoxy resin. Thru-hole, J, Gull Wing or Tucked Lead configurations are available on these modules (see Part Number Table note to specify). Leads meet the solderability requirements of MIL-STD-202, Method 208. Corner standoffs on the housing of the thru-hole lead version and lead design of the surface mount versions provide positive standoff from the printed circuit board to permit solder-fillet formation and flush cleaning of solder-flux residues for improved reliability.

Marking consists of manufacturer's name, logo (EC²), part number, terminal identification and date code of manufacture. All marking is applied by silk screen process using white epoxy paint in accordance with MIL-STD-130, to meet the permanency of identification required by MIL-STD-202, Method 215.



**engineered
components
company**

P.O. Box 8121 • San Luis Obispo CA 93403-8121
From California (805) 544-3800
Toll Free (800) 235-4144
FAX (805) 544-8091

www.ec2.com or
www.engineeredcomponents.com
info@ec2.com or
info@engineeredcomponents.com

BLOCK DIAGRAM IS SHOWN BELOW

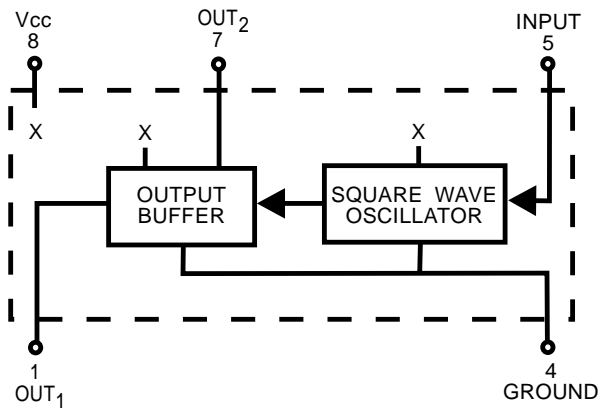

MECHANICAL DETAIL IS SHOWN BELOW

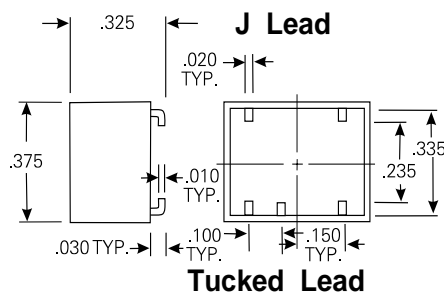
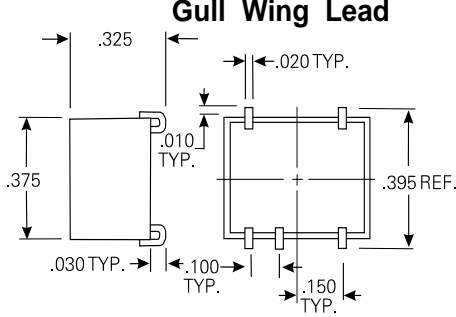
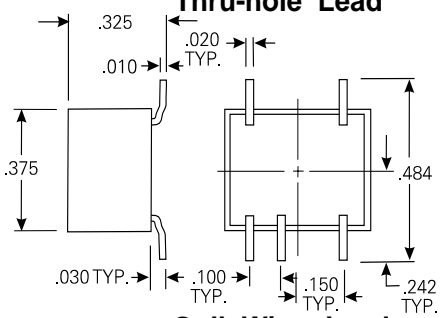
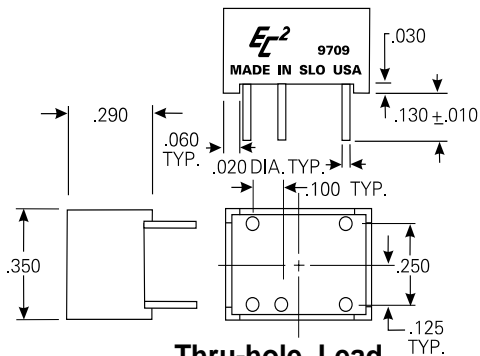
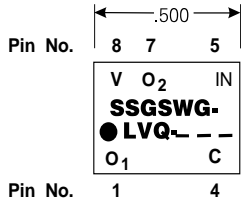

TEST CONDITIONS

1. All measurements are made at 25°C.
2. V_{CC} supply voltage is maintained at 3.3V DC.
3. All units are tested using a LVQ gate driving the input and one LVQ gate load at the output.

OPERATING SPECIFICATIONS

* V_{CC} supply voltage: 2.7 to 3.6V DC
 V_{CC} supply current:
 SSGSWG-LVQ-2 4mA typical
 SSGSWG-LVQ-80 20mA typical
 (Current increases with operating frequency)

Logic 1 Input:
 Voltage 2V min.; V_{CC} max.
 Current V_{CC} max.; 1uA max.

Logic 0 Input:
 Voltage8V max.
 Current 1uA max.

Logic 1 Voltage out: 2.2V min.; V_{CC} 3.0;
 I_{OH} -12mA

Logic 0 Voltage out:4V max. I_{OL} +12mA
 Operating temperature range: -40 to +85°C.
 Storage temperature: -55 to +125°C.

* Output frequency will increase or decrease less than 2% for a respective increase or decrease of 10% in supply voltage.

PART NUMBER TABLE

Suffix Part Number with G (for Gull Wing Lead), J (for J Lead), F (for Thru-hole Lead) or T (for Tucked Lead). Examples: SSGSWG-LVQ-10G (Gull Wing), SSGSWG-LVQ-25J (J Lead), SSGSWG-LVQ-70F (Thru-hole Lead) or SSGSWG-LVQ-12T (Tucked Lead).

PART NUMBER	OUTPUT FREQUENCY	PART NUMBER	OUTPUT FREQUENCY
SSGSWG-LVQ-2	2.0 MHz	SSGSWG-LVQ-12	12.0 MHz
SSGSWG-LVQ-2.5	2.5 MHz	SSGSWG-LVQ-13	13.0 MHz
SSGSWG-LVQ-3	3.0 MHz	SSGSWG-LVQ-14	14.0 MHz
SSGSWG-LVQ-3.5	3.5 MHz	SSGSWG-LVQ-15	15.0 MHz
SSGSWG-LVQ-4	4.0 MHz	SSGSWG-LVQ-20	20.0 MHz
SSGSWG-LVQ-4.5	4.5 MHz	SSGSWG-LVQ-25	25.0 MHz
SSGSWG-LVQ-5	5.0 MHz	SSGSWG-LVQ-30	30.0 MHz
SSGSWG-LVQ-5.5	5.5 MHz	SSGSWG-LVQ-35	35.0 MHz
SSGSWG-LVQ-6	6.0 MHz	SSGSWG-LVQ-40	40.0 MHz
SSGSWG-LVQ-7	7.0 MHz	SSGSWG-LVQ-45	45.0 MHz
SSGSWG-LVQ-8	8.0 MHz	SSGSWG-LVQ-50	50.0 MHz
SSGSWG-LVQ-9	9.0 MHz	SSGSWG-LVQ-60	60.0 MHz
SSGSWG-LVQ-10	10.0 MHz	SSGSWG-LVQ-70	70.0 MHz
SSGSWG-LVQ-11	11.0 MHz	SSGSWG-LVQ-80	80.0 MHz

Special modules can be readily manufactured to improve accuracies and/or provide customer specified non-standard frequencies for specific applications.