

## BLOCK DIAGRAM IS SHOWN BELOW

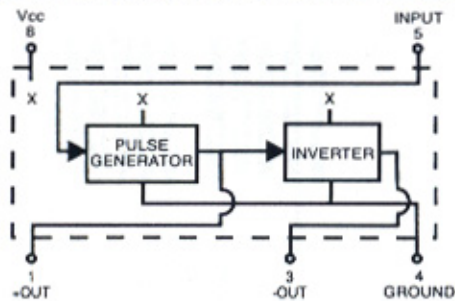

## MECHANICAL DETAIL IS SHOWN BELOW

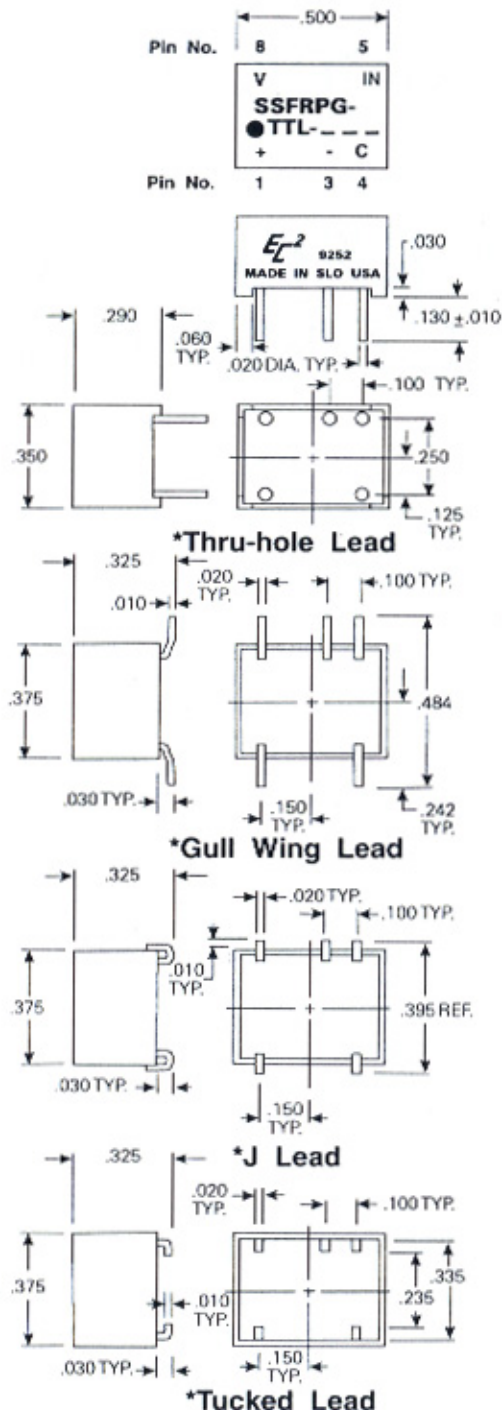

## OPERATING SPECIFICATIONS

*V <sub>CC</sub> supply voltage: . . . . .	4.75 to 5.25V DC
V <sub>CC</sub> supply current:	
Constant "0" in . . . . .	40mA typical
Constant "1" in . . . . .	40mA typical
Logic 1 Input:	
Voltage . . . . .	2V min.; V <sub>CC</sub> max.
Current . . . . .	2.7V = 20uA max. @ max. V in = 100uA max.
Logic 0 Input:	
Voltage . . . . .	.8V max.
Current . . . . .	-2mA max.
Logic 1 Voltage out: . . . . .	2.5V min.
Logic 0 Voltage out: . . . . .	.5V max.
Operating temperature range: . . . . .	0 to +70°C.
Storage temperature: . . . . .	-55 to +125°C.

\* Pulse width increases or decreases approximately 1% for a respective decrease or increase of 5% in supply voltage.

## PART NUMBER TABLE

\*Suffix Part Number with G (for Gull Wing Lead), J (for J Lead), F (for Thru-hole Lead) or T (for Tucked Lead). Examples: SSFRPG-TTL-10G (Gull Wing), SSFRPG-TTL-25J (J Lead), SSFRPG-TTL-75F (Thru-hole Lead) or SSFRPG-TTL-12T (Tucked Lead).

PART NUMBER	PULSE WIDTH (in ns)	MAXIMUM REP. RATE (in MHz)
SSFRPG-TTL-10	10 ±1	60.0
SSFRPG-TTL-11	11 ±1	56.0
SSFRPG-TTL-12	12 ±1	53.0
SSFRPG-TTL-13	13 ±1	51.0
SSFRPG-TTL-14	14 ±1	48.0
SSFRPG-TTL-15	15 ±1	46.0
SSFRPG-TTL-16	16 ±1	44.0
SSFRPG-TTL-17	17 ±1	42.0
SSFRPG-TTL-18	18 ±1	40.0
SSFRPG-TTL-19	19 ±1	38.0
SSFRPG-TTL-20	20 ±1	37.0
SSFRPG-TTL-21	21 ±1	35.0
SSFRPG-TTL-22	22 ±1	34.0
SSFRPG-TTL-23	23 ±1	33.0
SSFRPG-TTL-24	24 ±1	32.0
SSFRPG-TTL-25	25 ±1	31.0
SSFRPG-TTL-30	30 ±1	26.0
SSFRPG-TTL-35	35 ±1.5	23.0
SSFRPG-TTL-40	40 ±1.5	20.0
SSFRPG-TTL-45	45 ±1.5	18.0
SSFRPG-TTL-50	50 ±1.5	17.0
SSFRPG-TTL-60	60 ±1.5	14.5
SSFRPG-TTL-70	70 ±2	12.5
SSFRPG-TTL-75	75 ±2	11.5
SSFRPG-TTL-80	80 ±2	11.0
SSFRPG-TTL-90	90 ±3	9.5
SSFRPG-TTL-100	100 ±3	8.5
SSFRPG-TTL-150	150 ±4	6.0
SSFRPG-TTL-200	200 ±6	4.5
SSFRPG-TTL-250	250 ±7	3.5
SSFRPG-TTL-300	300 ±9	3.0
SSFRPG-TTL-400	400 ±10	2.2
SSFRPG-TTL-500	500 ±10	1.8

All modules can be operated up to the maximum pulse rate specified in the Part Number Table with pulse widths as low as 10ns and pulse spacing as low as 10ns. Since pulse width accuracies may be somewhat degraded at high pulse rates, it is suggested that the module be evaluated under the specific operating conditions. **Special modules can be readily manufactured to improve accuracies and/or provide customer specified non-standard pulse widths for specific applications.**

## TEST CONDITIONS

1. All measurements are made at 25°C.
2. V<sub>CC</sub> supply voltage is maintained at 5.0V DC.
3. All units are tested using a Schottky toggle-type positive input pulse and one Schottky T<sup>2</sup>L load at the output.
4. Input pulse width used is 10ns for all modules; repetition rate is approximately 200 KHz.