

BLOCK DIAGRAM IS SHOWN BELOW

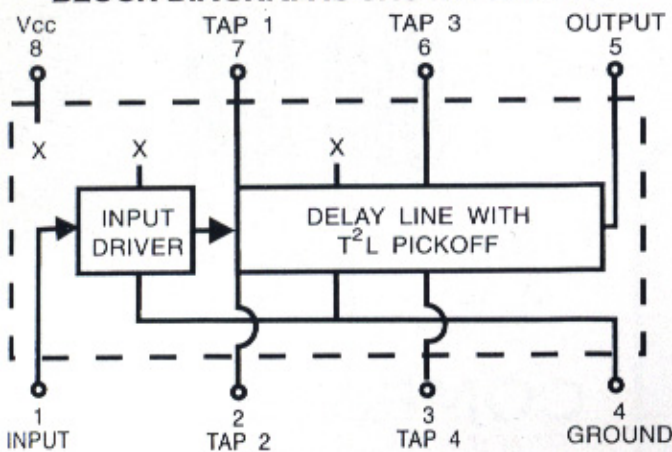

MECHANICAL DETAIL IS SHOWN BELOW

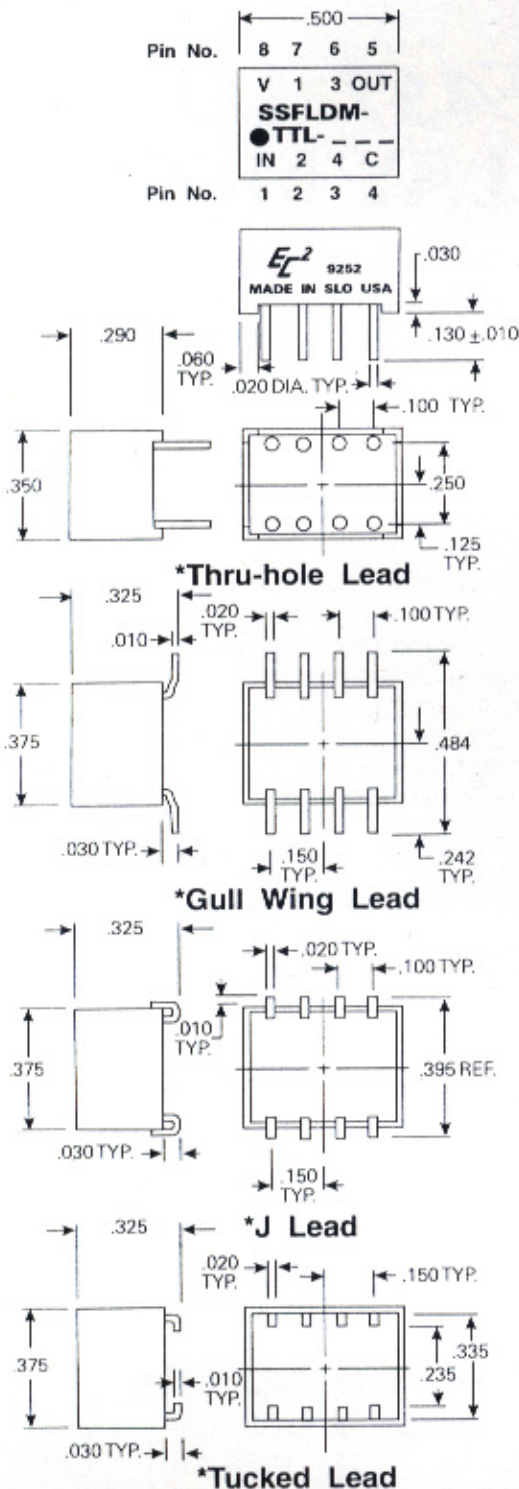

TEST CONDITIONS

1. All measurements are made at 25°C.
2. V_{cc} supply voltage is maintained at 5.0V DC.
3. All units are tested using a Schottky toggle-type positive input pulse and one Schottky load at the output being tested.
4. Input pulse width used is 5 to 10ns longer than delay of module under test; spacing between pulses (falling edge to rising edge) is three times the pulse width used.

OPERATING SPECIFICATIONS

- * V_{cc} supply voltage: 4.75 to 5.25V DC
- V_{cc} supply current;
 - Constant "0" in **40mA typical**
 - Constant "1" in **7mA typical**
- Logic 1 Input:
 - Voltage 2V min.; V_{cc} max.
 - Current 2.7V = 20uA max.
 - 5.5V = 1mA max.
- Logic 0 Input:
 - Voltage8V max.
 - Current -.6mA max.
- Logic 1 Voltage out: 2.7V min.
- Logic 0 Voltage out:5V max.
- Operating temperature range: 0 to 70°C
- Storage temperature: -55 to +125°C.

* Delays increase or decrease approximately 2% for a respective increase or decrease of 5% in supply voltage.

PART NUMBER TABLE

*Suffix Part Number with G (for Gull Wing Lead), J (for J Lead), F (for Thru-hole Lead) or T (for Tucked Lead). Examples: SSFLDM-TTL-10G (Gull Wing), SSFLDM-TTL-25J (J Lead), SSFLDM-TTL-75F (Thru-hole Lead) or SSFLDM-TTL-12T (Tucked Lead).

∅ DELAYS AND TOLERANCES (in ns)					
PART NO.	TAP 1	TAP 2	TAP 3	TAP 4	OUTPUT
SSFLDM-TTL-10	6 ±1	7 ±1	8 ±1	9 ±1	10 ±1
SSFLDM-TTL-12	6 ±1	7.5 ±1	9 ±1	10.5 ±1	12 ±1
SSFLDM-TTL-14	6 ±1	8 ±1	10 ±1	12 ±1	14 ±1
SSFLDM-TTL-16	6 ±1	8.5 ±1	11 ±1	13.5 ±1	16 ±1
SSFLDM-TTL-18	6 ±1	9 ±1	12 ±1	15 ±1	18 ±1
SSFLDM-TTL-22	6 ±1	10 ±1	14 ±1	18 ±1	22 ±1
SSFLDM-TTL-25	5 ±1	10 ±1	15 ±1	20 ±1	25 ±1
SSFLDM-TTL-30	6 ±1	12 ±1	18 ±1	24 ±1	30 ±1
SSFLDM-TTL-35	7 ±1	14 ±1	21 ±1	28 ±1.5	35 ±1.5
SSFLDM-TTL-40	8 ±1	16 ±1	24 ±1.5	32 ±1.5	40 ±1.5
SSFLDM-TTL-45	9 ±1	18 ±1	27 ±1.5	36 ±1.5	45 ±2
SSFLDM-TTL-50	10 ±1	20 ±1	30 ±1.5	40 ±2	50 ±2
SSFLDM-TTL-55	11 ±1	22 ±1	33 ±1.5	44 ±2	55 ±2
SSFLDM-TTL-60	12 ±1	24 ±1	36 ±1.5	48 ±2	60 ±2
SSFLDM-TTL-65	13 ±1	26 ±1.5	39 ±1.5	52 ±2	65 ±2.5
SSFLDM-TTL-70	14 ±1	28 ±1.5	42 ±2	56 ±2	70 ±2.5
SSFLDM-TTL-75	15 ±1	30 ±1.5	45 ±2	60 ±2.5	75 ±2.5
SSFLDM-TTL-80	16 ±1	32 ±1.5	48 ±2	64 ±2.5	80 ±3
SSFLDM-TTL-85	17 ±1	34 ±1.5	51 ±2	68 ±2.5	85 ±3
SSFLDM-TTL-90	18 ±1	36 ±1.5	54 ±2	72 ±2.5	90 ±3
SSFLDM-TTL-95	19 ±1	38 ±1.5	57 ±2	76 ±2.5	95 ±3
SSFLDM-TTL-100	20 ±1	40 ±1.5	60 ±2	80 ±3	100 ±3
SSFLDM-TTL-125	25 ±1	50 ±2	75 ±2.5	100 ±3	125 ±4
SSFLDM-TTL-150	30 ±1.5	60 ±2	90 ±3	120 ±4	150 ±5
SSFLDM-TTL-175	35 ±1.5	70 ±2.5	105 ±4	140 ±5	175 ±5
SSFLDM-TTL-200	40 ±1.5	80 ±2.5	120 ±4	160 ±5	200 ±6
SSFLDM-TTL-225	45 ±2	90 ±3	135 ±4	180 ±6	225 ±7
SSFLDM-TTL-250	50 ±2	100 ±3	150 ±4.5	200 ±6	250 ±8
SSFLDM-TTL-300	60 ±2	120 ±4	180 ±5	240 ±7	300 ±9
SSFLDM-TTL-350	70 ±2	140 ±4.5	210 ±7	280 ±9	350 ±11
SSFLDM-TTL-400	80 ±3	160 ±5	240 ±7	320 ±10	400 ±12
SSFLDM-TTL-450	90 ±3	180 ±6	270 ±8	360 ±11	450 ±14
SSFLDM-TTL-500	100 ±3	200 ±6	300 ±9	400 ±12	500 ±15

∅ All modules can be operated with a minimum input pulse width of 40% of full delay and pulse period approaching square wave; since delay accuracies may be somewhat degraded, it is suggested that the module be evaluated under the intended specific operating conditions. Special modules can be readily manufactured to improve accuracies and/or provide customer specified random delay times for specific applications.