

MECHANICAL DETAIL IS SHOWN BELOW

BLOCK DIAGRAM IS SHOWN BELOW

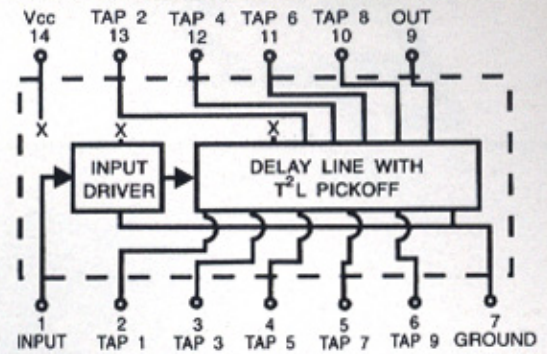
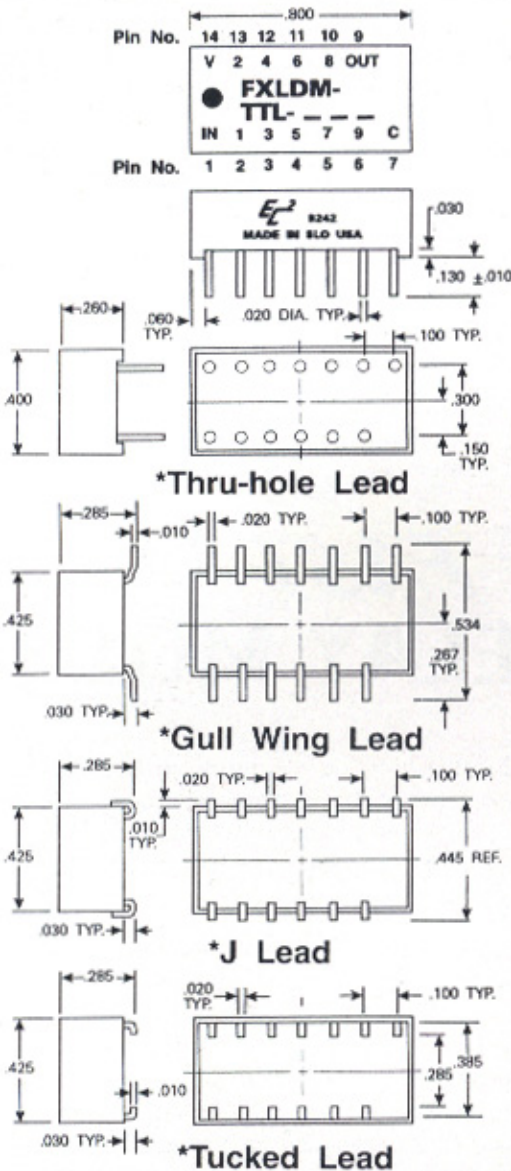

TEST CONDITIONS

1. All measurements are made at 25°C.
2. V_{CC} supply voltage is maintained at 5.0V DC.
3. All units are tested using a Schottky toggle-type positive input pulse and one Schottky load at the output being tested.
4. Input pulse width used is 5 to 10ns longer than delay of module under test; spacing between pulses (falling edge to rising edge) is three times the pulse width used.

OPERATING SPECIFICATIONS

* V_{CC} supply voltage: 4.75 to 5.25V DC
 V_{CC} supply current:
 Constant '0' in 45mA typical
 Constant '1' in 15mA typical

Logic 1 Input:
 Voltage 2V min.; V_{CC} max.
 Current 2.7V = 20uA max.
 5.5V = 1mA max.

Logic 0 Input:
 Voltage8V max.
 Current -6mA max.

Logic 1 Voltage out: 2.7V min.
 Logic 0 Voltage out:5V max.
 Operating temperature range: 0 to 70°C
 Storage temperature: -55 to +125°C.

* Delays increase or decrease approximately 2% for a respective increase or decrease of 5% in supply voltage.

PART NUMBER TABLE

*Suffix Part Number with G (for Gull Wing Lead), J (for J Lead), F (for Thru-hole Lead) or T (for Tucked Lead).
 Examples: FXLDM-TTL-50G (Gull Wing), FXLDM-TTL-70J (J Lead), FXLDM-TTL-80F (Thru-hole Lead) or FXLDM-TTL-90T (Tucked Lead).

Ø DELAYS AND TOLERANCES (in ns)										
PART NO.	TAP 1	TAP 2	TAP 3	TAP 4	TAP 5	TAP 6	TAP 7	TAP 8	TAP 9	OUTPUT
FXLDM-TTL-15	6 ±1	7 ±1	8 ±1	9 ±1	10 ±1	11 ±1	12 ±1	13 ±1	14 ±1	15 ±1
FXLDM-TTL-19.5	6 ±1	7.5 ±1	9 ±1	10.5 ±1	12 ±1	13.5 ±1	15 ±1	16.5 ±1	18 ±1	19.5 ±1
FXLDM-TTL-24	6 ±1	8 ±1	10 ±1	12 ±1	14 ±1	16 ±1	18 ±1	20 ±1	22 ±1	24 ±1
FXLDM-TTL-28.5	6 ±1	8.5 ±1	11 ±1	13.5 ±1	16 ±1	18.5 ±1	21 ±1	23.5 ±1	26 ±1.5	28 ±1.5
FXLDM-TTL-33	6 ±1	9 ±1	12 ±1	15 ±1	18 ±1	21 ±1	24 ±1	27 ±1.5	30 ±1.5	33 ±1.5
FXLDM-TTL-42	6 ±1	10 ±1	14 ±1	18 ±1	22 ±1	26 ±1.5	30 ±1.5	34 ±1.5	38 ±2	42 ±2
FXLDM-TTL-50	5 ±1	10 ±1	15 ±1	20 ±1	25 ±1.5	30 ±1.5	35 ±1.5	40 ±2	45 ±2	50 ±2
FXLDM-TTL-60	6 ±1	12 ±1	18 ±1	24 ±1	30 ±1.5	36 ±1.5	42 ±2	48 ±2	54 ±2	60 ±2.5
FXLDM-TTL-70	7 ±1	14 ±1	21 ±1	28 ±1.5	35 ±1.5	42 ±2	49 ±2	56 ±2	62 ±2.5	70 ±2.5
FXLDM-TTL-80	8 ±1	16 ±1	24 ±1	32 ±1.5	40 ±2	48 ±2	56 ±2	64 ±2.5	72 ±2.5	80 ±3
FXLDM-TTL-90	9 ±1	18 ±1	27 ±1.5	36 ±1.5	45 ±2	54 ±2	63 ±2.5	72 ±2.5	81 ±3	90 ±3
FXLDM-TTL-100	10 ±1	20 ±1	30 ±1.5	40 ±2	50 ±2	60 ±2.5	70 ±2.5	80 ±3	90 ±3	100 ±3
FXLDM-TTL-125	12.5 ±1	25 ±1.5	37.5 ±2	50 ±2	62.5 ±2.5	75 ±2.5	87.5 ±3	100 ±3	112.5 ±4	125 ±4
FXLDM-TTL-150	15 ±1	30 ±1.5	45 ±2	60 ±2.5	75 ±2.5	90 ±3	105 ±4	120 ±4	135 ±4	150 ±5
FXLDM-TTL-175	17.5 ±1	35 ±2	52.5 ±2	70 ±2.5	87.5 ±3	105 ±4	122.5 ±4	140 ±5	157.5 ±5	175 ±5
FXLDM-TTL-200	20 ±1	40 ±2	60 ±2.5	80 ±3	100 ±3	120 ±4	140 ±5	160 ±5	180 ±6	200 ±6
FXLDM-TTL-250	25 ±1.5	50 ±2	75 ±2.5	100 ±3	125 ±4	150 ±5	175 ±5	200 ±6	225 ±7	250 ±8
FXLDM-TTL-300	30 ±1.5	60 ±2.5	90 ±3	120 ±4	150 ±5	180 ±6	210 ±7	240 ±7	270 ±8	300 ±9
FXLDM-TTL-350	35 ±1.5	70 ±2.5	105 ±4	140 ±5	175 ±5	210 ±7	245 ±8	280 ±9	315 ±10	350 ±11
FXLDM-TTL-400	40 ±2	80 ±3	120 ±4	160 ±5	200 ±6	240 ±7	280 ±9	320 ±10	360 ±11	400 ±12
FXLDM-TTL-450	45 ±2	90 ±3	135 ±4	180 ±6	225 ±7	270 ±8	315 ±10	360 ±11	405 ±12	450 ±14
FXLDM-TTL-500	50 ±2	100 ±3	150 ±5	200 ±6	250 ±8	300 ±9	350 ±11	400 ±12	450 ±14	500 ±15
FXLDM-TTL-600	60 ±2.5	120 ±4	180 ±5	240 ±7	300 ±9	360 ±11	420 ±13	480 ±15	540 ±16	600 ±18
FXLDM-TTL-700	70 ±2.5	140 ±5	210 ±7	280 ±9	350 ±11	420 ±13	490 ±15	560 ±17	630 ±19	700 ±20
FXLDM-TTL-800	80 ±3	160 ±5	240 ±7	320 ±10	400 ±12	480 ±15	560 ±17	640 ±19	720 ±20	800 ±20
FXLDM-TTL-900	90 ±3	180 ±6	270 ±8	360 ±11	450 ±14	540 ±16	630 ±19	720 ±20	810 ±20	900 ±22
FXLDM-TTL-1000	100 ±3	200 ±6	300 ±9	400 ±12	500 ±15	600 ±18	700 ±20	800 ±20	900 ±22	1000 ±22

Ø All modules can be operated with a minimum input pulse width of 20% of full delay or 5ns min and pulse period approaching square wave; since delay accuracies may be somewhat degraded, it is suggested that the module be evaluated under the intended specific operating conditions. Special modules can be readily manufactured to improve accuracies and/or provide customer specified random delay times for specific applications.