

## DESIGN NOTES (continued)

Marking consists of manufacturer's logo (EC<sup>2</sup>), part number, terminal identification and date code of manufacture. All marking is applied by silk screen process using white epoxy paint in accordance with MIL-STD-130, to meet the permanency of identification required by MIL-STD-202, Method 215.

BLOCK DIAGRAM IS SHOWN BELOW

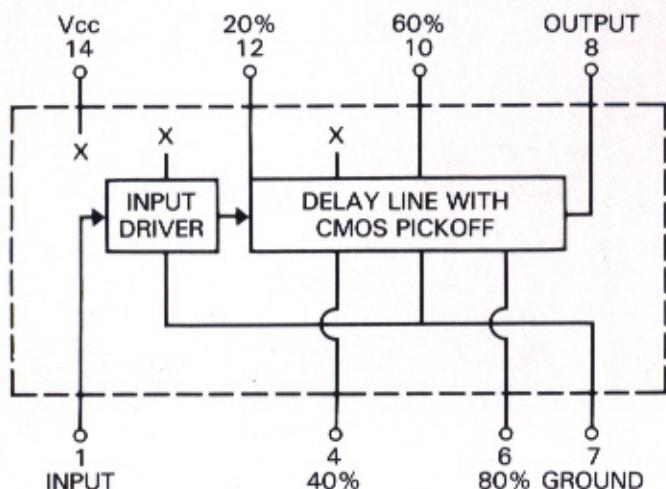

MECHANICAL DETAIL IS SHOWN BELOW

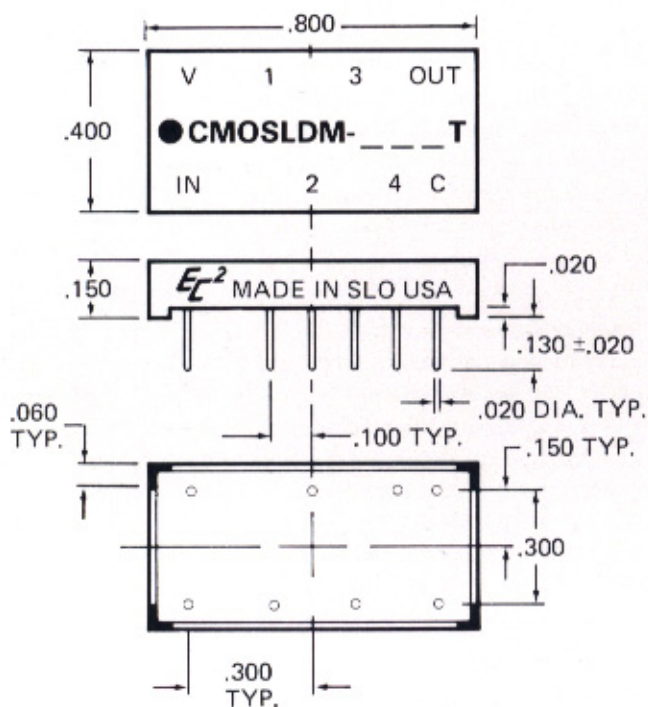

## TEST CONDITIONS

- All measurements are made at 25°C.
- V<sub>CC</sub> supply voltage is maintained at 5.0V DC.
- All units are tested using a CMOS positive input pulse and one CMOS load at the output being tested.
- Input pulse width used is 5 to 10ns longer than full delay of module under test; spacing between pulses (falling edge to rising edge) is three times the pulse width used.

## OPERATING SPECIFICATIONS

- \*V<sub>CC</sub> supply voltage: . . . . . 4.5 to 5.5V DC
- V<sub>CC</sub> supply current:
- \*\* Constant "0" in . . . . . 7 to 13ma typical
- Constant "1" in . . . . . .1ua typical

Logic 1 input:

- Voltage . . . . . 2V min.; 5.5V max.
- Current . . . . . 2.4V = 1ua max.

Logic 0 input:

- Voltage . . . . . .8V max.
- Current . . . . . 1ua max.

Logic 1 Voltage out: . . . . . 3.84V min.

Logic 0 Voltage out: . . . . . .33V max.

Operating temperature range: . . . . . -40 to +85°C.

Storage temperature: . . . . . -55 to +125°C.

\*Delays decrease or increase approximately 1% or 1ns, whichever is greater, for a respective increase or decrease of 5% in supply voltage.

\*\* 7ma typical through CMOSLDM-100T and 13ma typical for parts CMOSLDM-125T and above.

## PART NUMBER TABLE

φ DELAYS AND TOLERANCES (in ns)					
PART NO.	Tap 1	Tap 2	Tap 3	Tap 4	OUTPUT
CMOSLDM-20T	16 ± 1	17 ± 1	18 ± 1	19 ± 1	20 ± 1
CMOSLDM-22T	16 ± 1	17.5 ± 1	19 ± 1	20.5 ± 1	22 ± 1
CMOSLDM-24T	16 ± 1	18 ± 1	20 ± 1	22 ± 1	24 ± 1
CMOSLDM-26T	16 ± 1	18.5 ± 1	21 ± 1	23.5 ± 1	26 ± 1
CMOSLDM-28T	16 ± 1	19 ± 1	22 ± 1	25 ± 1	28 ± 1
CMOSLDM-32T	16 ± 1	20 ± 1	24 ± 1	28 ± 1	32 ± 1
CMOSLDM-35T	15 ± 1	20 ± 1	25 ± 1	30 ± 1.5	35 ± 1.5
CMOSLDM-39T	15 ± 1	21 ± 1	27 ± 1.5	33 ± 1.5	39 ± 1.5
CMOSLDM-43T	15 ± 1	22 ± 1	29 ± 1.5	36 ± 1.5	43 ± 1.5
CMOSLDM-47T	15 ± 1	23 ± 1	31 ± 1.5	39 ± 1.5	47 ± 1.5
CMOSLDM-51T	15 ± 1	24 ± 1	33 ± 1.5	42 ± 1.5	51 ± 2
CMOSLDM-55T	15 ± 1	25 ± 1	35 ± 1.5	45 ± 2	55 ± 2
CMOSLDM-59T	15 ± 1	26 ± 1	37 ± 1.5	48 ± 2	59 ± 2.5
CMOSLDM-63T	15 ± 1	27 ± 1	39 ± 1.5	51 ± 2	63 ± 2.5
CMOSLDM-67T	15 ± 1	28 ± 1.5	41 ± 1.5	54 ± 2	67 ± 2.5
CMOSLDM-71T	15 ± 1	29 ± 1.5	43 ± 1.5	57 ± 2	71 ± 2.5
CMOSLDM-75T	15 ± 1	30 ± 1.5	45 ± 2	60 ± 2.5	75 ± 2.5
CMOSLDM-80T	16 ± 1	32 ± 1.5	48 ± 2	64 ± 2.5	80 ± 3
CMOSLDM-85T	17 ± 1	34 ± 1.5	51 ± 2	68 ± 2.5	85 ± 3
CMOSLDM-90T	18 ± 1	36 ± 1.5	54 ± 2	72 ± 2.5	90 ± 3
CMOSLDM-95T	19 ± 1	38 ± 1.5	57 ± 2	76 ± 2.5	95 ± 3
CMOSLDM-100T	20 ± 1	40 ± 1.5	60 ± 2	80 ± 3	100 ± 3
CMOSLDM-125T	25 ± 1	50 ± 2	75 ± 2.5	100 ± 3	125 ± 4
CMOSLDM-150T	30 ± 1.5	60 ± 2	90 ± 3	120 ± 4	150 ± 5
CMOSLDM-175T	35 ± 1.5	70 ± 2.5	105 ± 4	140 ± 5	175 ± 5
CMOSLDM-200T	40 ± 1.5	80 ± 3	120 ± 4	160 ± 5	200 ± 6
CMOSLDM-225T	45 ± 2	90 ± 3	135 ± 4	180 ± 6	225 ± 7
CMOSLDM-250T	50 ± 2	100 ± 3	150 ± 5	200 ± 6	250 ± 8

φ All modules can be operated with a minimum input pulse width of 40% of full delay and pulse period approaching square wave; since delay accuracies may be somewhat degraded, it is suggested that the module be evaluated under the intended specific operating conditions. **Special modules can be readily manufactured to improve accuracies and/or provide customer specified random delay times for specific applications.**