

# EC<sup>2</sup>

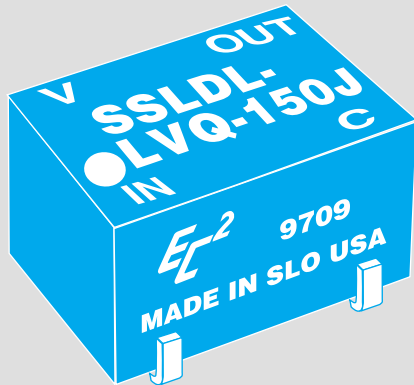

# space saver

## LVQ 3V

# LOGIC DELAY LINE

- T<sup>2</sup>L LV CMOS input and output
- Delay stable and precise
- 8-pin Space Saver package
- Leads - thru-hole, J, Gull Wing or Tucked
- Available in delays from 6 to 150ns
- Fast rise time on output
- 12mA output drive capability

## design notes

The LVQ "Space Saver Series" Logic Delay Lines developed by Engineered Components Company have been designed to provide precise delays with required driving and pick-off circuitry contained in a single 8-pin package compatible with low voltage (3.3V) & T<sup>2</sup>L circuits. These logic delay lines are of hybrid construction utilizing the proven technologies of active integrated circuitry and of passive networks utilizing capacitive, inductive and resistive elements. The MTBF on these modules, when calculated per MIL-HDBK-217 for a 50°C ground fixed environment, is in excess of 4 million hours. Module design includes compensation for propagation delays and incorporates internal termination at the output; no additional external components are needed to obtain the specified delay.

The SSLDL-LVQ is offered in 37 delays from 6 to 150ns. Delay tolerances are maintained as shown in the accompanying part number table, when tested under the "Test Conditions" shown.

Delay time is measured at the +1.5V level on the leading edge. Output is capable of driving  $\pm 12\text{mA}$ . Temperature coefficient of delay is approximately +1200 ppm/°C over the operating temperature range of -40 to +85°C.

These modules accept either logic "1" or logic "0" inputs and reproduce the logic at the output without inversion. The delay modules are intended primarily for use with positive going pulses and are calibrated to the tolerances shown in the table on rising edge delay; where best accuracy is desired in applications using falling edge timing, it is recommended that a special unit be calibrated for the specific application.

These LVQ "Space Saver Series" modules are packaged in an 8-pin housing, molded of flame-proof Diallyl Phthalate per MIL-M-14, Type SDG-F, and are fully encapsulated in epoxy resin. Thru-hole, J, Gull Wing or Tucked Lead configurations are available on these modules (see Part Number Table note to specify). Leads meet the solderability requirements of MIL-STD-202, Method 208. Corner standoffs on the housing of the thru-hole lead version and lead design of the surface mount versions provide positive standoff from the printed circuit board to permit solder-fillet formation and flush cleaning of solder-flux residues for improved reliability.

Marking consists of manufacturer's name, logo (EC<sup>2</sup>), part number, terminal identification and date code of manufacture. All marking is applied by silk screen process using white epoxy paint in accordance with MIL-STD-130, to meet the permanency of identification required by MIL-STD-202, Method 215.



**engineered  
components  
company**

P.O. Box 8121 • San Luis Obispo CA 93403-8121

From California (805) 544-3800

Toll Free (800) 235-4144

FAX (805) 544-8091

www.ec2.com *or*  
www.engineeredcomponents.com  
info@ec2.com *or*  
info@engineeredcomponents.com

**BLOCK DIAGRAM IS SHOWN BELOW**

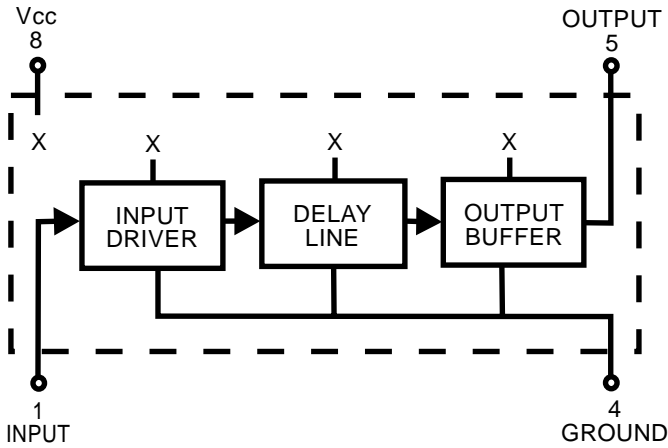

**MECHANICAL DETAIL IS SHOWN BELOW**

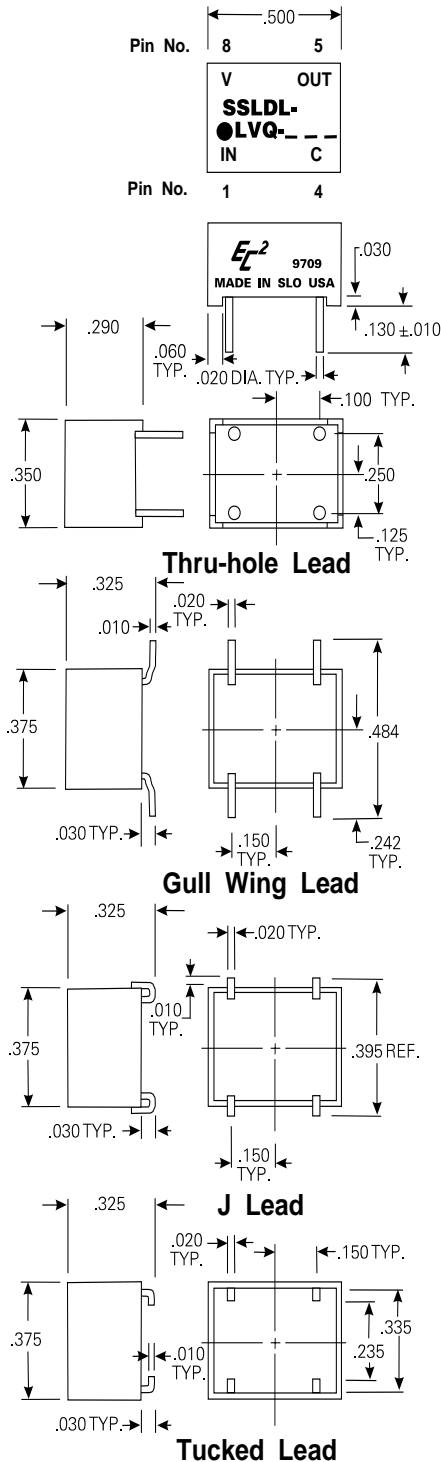

**TEST CONDITIONS**

1. All measurements are made at 25°C.
2. V<sub>CC</sub> supply voltage is maintained at 3.3V DC.
3. All units are tested using a LVQ gate providing a positive input pulse and one LVQ gate load at the output.
- Ø4. Input pulse width used is 100% longer than delay of module under test; spacing between pulses (falling edge to rising edge) is three times the pulse width used.

**OPERATING SPECIFICATIONS**

\* V<sub>CC</sub> supply voltage: . . . . . 2.7 to 3.6V DC  
 V<sub>CC</sub> supply current:  
 Constant "0" or "1" . . . . . 1µA max.  
 1MHz square wave input . . . . . 1mA typical

Logic 1 Input:  
 Voltage . . . . . 2V min.; V<sub>CC</sub> max.  
 Current . . . . . V<sub>CC</sub> max.; 1µA max.  
 Logic 0 Input:  
 Voltage . . . . . .8V max.  
 Current . . . . . 1µA max.

Logic 1 Voltage out: . . . . . 2.2V min.; V<sub>CC</sub> 3.0;  
 I<sub>OH</sub> -12mA  
 Logic 0 Voltage out: . . . . . .4V max. I<sub>OL</sub> +12mA  
 Operating temperature range: . . . . . -40 to +85°C  
 Storage temperature: . . . . . -55 to +125°C.

\* Delays increase or decrease approximately 2% for a respective increase or decrease of 10% in supply voltage.

**PART NUMBER TABLE**

**Suffix Part Number with G (for Gull Wing Lead), J (for J Lead), F (for Thru-hole Lead) or T (for Tucked Lead).**  
**Examples: SSLDL-LVQ-10G (Gull Wing), SSLDL-LVQ-25J (J Lead), SSLDL-LVQ-70F (Thru-hole Lead) or SSLDL-LVQ-15T (Tucked Lead).**

Ø DELAYS AND TOLERANCES (In ns)			
PART NUMBER	OUTPUT	PART NUMBER	OUTPUT
SSLDL-LVQ-6	6±.5	SSLDL-LVQ-25	25±1
SSLDL-LVQ-7	7±.5	SSLDL-LVQ-30	30±1.5
SSLDL-LVQ-8	8±.5	SSLDL-LVQ-35	35±1.5
SSLDL-LVQ-9	9±.5	SSLDL-LVQ-40	40±1.5
SSLDL-LVQ-10	10±.5	SSLDL-LVQ-45	45±2
SSLDL-LVQ-11	11±.75	SSLDL-LVQ-50	50±2
SSLDL-LVQ-12	12±.75	SSLDL-LVQ-55	55±2
SSLDL-LVQ-13	13±.75	SSLDL-LVQ-60	60±2
SSLDL-LVQ-14	14±.75	SSLDL-LVQ-65	65±2.5
SSLDL-LVQ-15	15±.75	SSLDL-LVQ-70	70±2.5
SSLDL-LVQ-16	16±.75	SSLDL-LVQ-75	75±2.5
SSLDL-LVQ-17	17±.75	SSLDL-LVQ-80	80±2.5
SSLDL-LVQ-18	18±.75	SSLDL-LVQ-85	85±3
SSLDL-LVQ-19	19±.75	SSLDL-LVQ-90	90±3
SSLDL-LVQ-20	20±.75	SSLDL-LVQ-95	95±3
SSLDL-LVQ-21	21±1	SSLDL-LVQ-100	100±3
SSLDL-LVQ-22	22±1	SSLDL-LVQ-125	125±4
SSLDL-LVQ-23	23±1	SSLDL-LVQ-150	150±4.5
SSLDL-LVQ-24	24±1		

ØAll modules can be operated with a minimum input pulse width of 100% of full delay or 15ns whichever is greater and pulse period approaching square wave; since delay accuracies may be somewhat degraded, it is suggested that the module be evaluated under the intended specific operating conditions. **Special modules can be readily manufactured to improve accuracies and/or provide customer specified random delay times for specific applications.**