

BLOCK DIAGRAM IS SHOWN BELOW

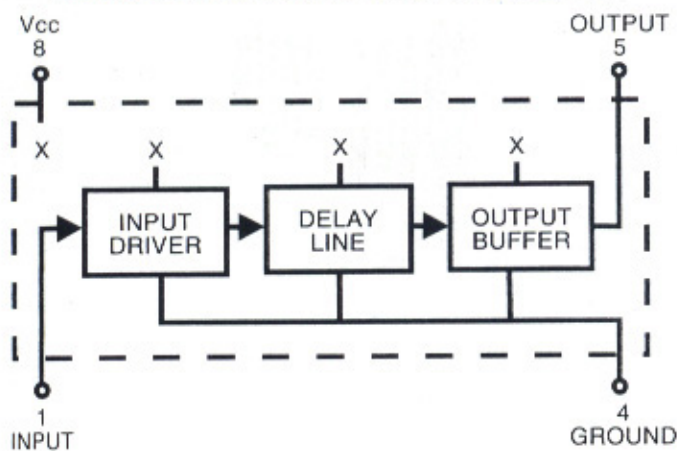

MECHANICAL DETAIL IS SHOWN BELOW

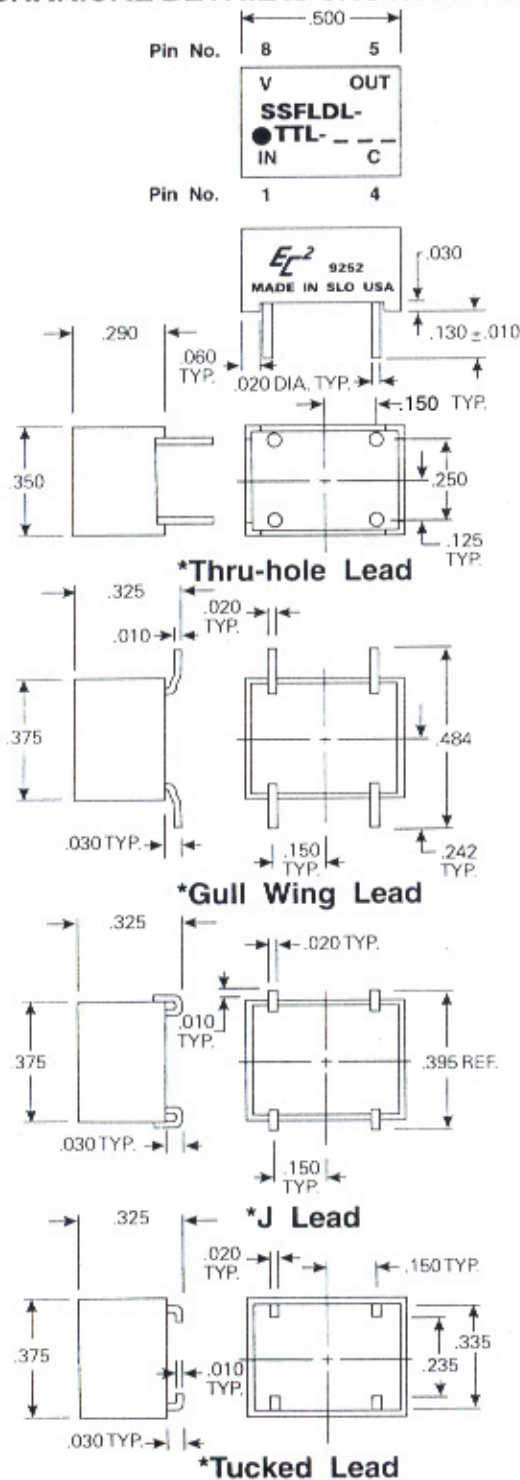

TEST CONDITIONS

1. All measurements are made at 25°C.
2. V_{CC} supply voltage is maintained at 5.0V DC.
3. All units are tested using a Schottky toggle-type positive input pulse and one Schottky load at the output.
4. Input pulse width used is 100% longer than delay of module under test; spacing between pulses (falling edge to rising edge) is three times the pulse width used.

OPERATING SPECIFICATIONS

*V _{CC} supply voltage:	4.75 to 5.25V DC
V _{CC} supply current:	
Constant "0" in	35mA typical
Constant "1" in	5mA typical

Logic 1 Input:	
Voltage	2V min.; V _{CC} max.
Current	2.7V = 20uA max. 5.5V = 1mA max.

Logic 0 Input:	
Voltage	.8V max.
Current	-.6mA max.

Logic 1 Voltage out:	2.7V min.
Logic 0 Voltage out:	.5V max.
Operating temperature range:	0 to 70°C
Storage temperature:	-55 to +125°C

* Delays increase or decrease approximately 2% for a respective increase or decrease of 5% in supply voltage.

PART NUMBER TABLE

*Suffix Part Number with G (for Gull Wing Lead), J (for J Lead), F (for Thru-hole Lead) or T (for Tucked Lead).
Examples: SSFLDL-TTL-10G (Gull Wing), SSFLDL-TTL-25J (J Lead), SSFLDL-TTL-70F (Thru-hole Lead) or SSFLDL-TTL-15T (Tucked Lead).

∅ DELAYS AND TOLERANCES (in ns)			
PART NO.	OUTPUT	PART NO.	OUTPUT
SSFLDL-TTL-5	5 ±.5	SSFLDL-TTL-45	45 ±2
SSFLDL-TTL-6	6 ±.5	SSFLDL-TTL-50	50 ±2
SSFLDL-TTL-7	7 ±.5	SSFLDL-TTL-55	55 ±2
SSFLDL-TTL-8	8 ±.5	SSFLDL-TTL-60	60 ±2
SSFLDL-TTL-9	9 ±.5	SSFLDL-TTL-65	65 ±2.5
SSFLDL-TTL-10	10 ±.5	SSFLDL-TTL-70	70 ±2.5
SSFLDL-TTL-11	11 ±.75	SSFLDL-TTL-75	75 ±2.5
SSFLDL-TTL-12	12 ±.75	SSFLDL-TTL-80	80 ±2.5
SSFLDL-TTL-13	13 ±.75	SSFLDL-TTL-85	85 ±3
SSFLDL-TTL-14	14 ±.75	SSFLDL-TTL-90	90 ±3
SSFLDL-TTL-15	15 ±.75	SSFLDL-TTL-95	95 ±3
SSFLDL-TTL-16	16 ±.75	SSFLDL-TTL-100	100 ±3
SSFLDL-TTL-17	17 ±.75	SSFLDL-TTL-125	125 ±4
SSFLDL-TTL-18	18 ±.75	SSFLDL-TTL-150	150 ±4.5
SSFLDL-TTL-19	19 ±.75	SSFLDL-TTL-175	175 ±5
SSFLDL-TTL-20	20 ±.75	SSFLDL-TTL-200	200 ±6
SSFLDL-TTL-21	21 ±1	SSFLDL-TTL-225	225 ±7
SSFLDL-TTL-22	22 ±1	SSFLDL-TTL-250	250 ±8
SSFLDL-TTL-23	23 ±1	SSFLDL-TTL-275	275 ±9
SSFLDL-TTL-24	24 ±1	SSFLDL-TTL-300	300 ±10
SSFLDL-TTL-25	25 ±1	SSFLDL-TTL-350	350 ±11
SSFLDL-TTL-30	30 ±1.5	SSFLDL-TTL-400	400 ±12
SSFLDL-TTL-35	35 ±1.5	SSFLDL-TTL-450	450 ±14
SSFLDL-TTL-40	40 ±1.5	SSFLDL-TTL-500	500 ±15

∅ All modules can be operated with a minimum input pulse width of 100% of full delay and pulse period approaching square wave; since delay accuracies may be somewhat degraded, it is suggested that the module be evaluated under the intended specific operating conditions. Special modules can be readily manufactured to improve accuracies and/or provide customer specified random delay times for specific applications.