

BLOCK DIAGRAM IS SHOWN BELOW

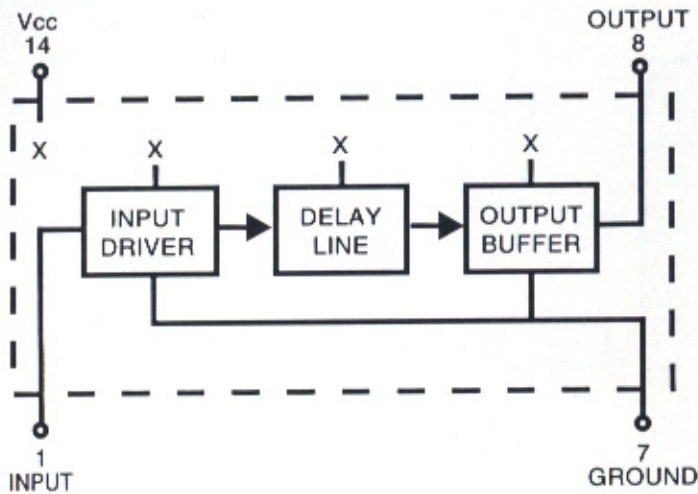

MECHANICAL DETAIL IS SHOWN BELOW

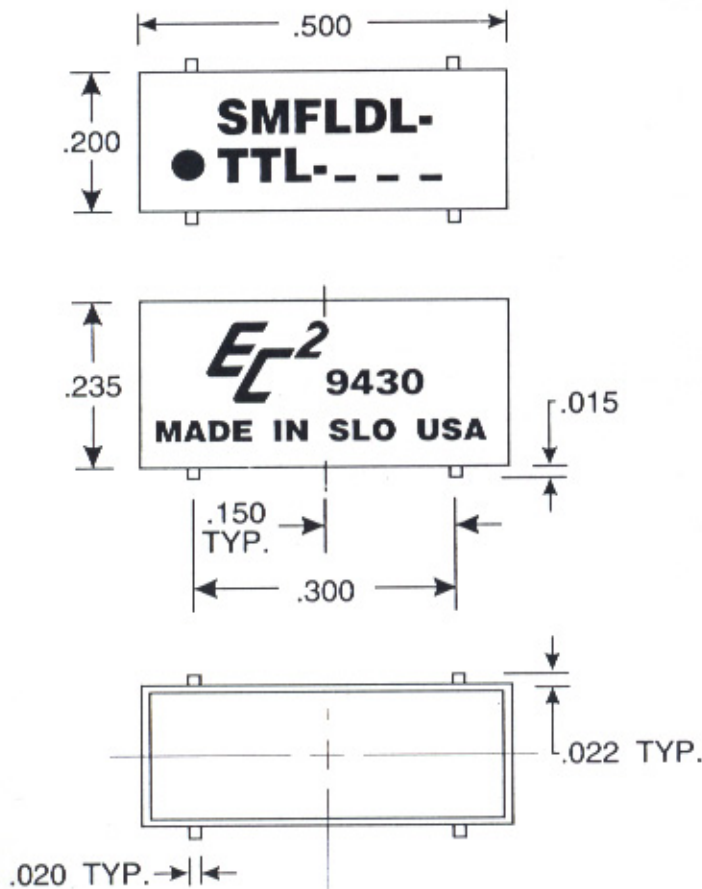

OPERATING SPECIFICATIONS

* V _{CC} supply voltage:	4.75 to 5.25V DC
V _{CC} supply current:	
Constant "0" in	40mA typical
Constant "1" in	7mA typical
Logic 1 Input:	
Voltage	2V min.; V _{CC} max.
Current	2.7V = 20uA max. 5.5V = 1mA max.
Logic 0 Input:	
Voltage	.8V max.
Current	-.6mA max.
Logic 1 Voltage out:	2.7V min.
Logic 0 Voltage out:	.5V max.
Operating temperature range:	0 to 70°C.
Storage temperature:	-55 to +125°C.

* Delays increase or decrease approximately 4% for a respective increase or decrease of 5% in supply voltage.

PART NUMBER TABLE

∅ DELAYS AND TOLERANCES (in ns)			
Part Number	Output	Part Number	Output
SMFLDL-TTL-5	5 ± 1	SMFLDL-TTL-130	130 ± 4
SMFLDL-TTL-6	6 ± 1	SMFLDL-TTL-140	140 ± 4.5
SMFLDL-TTL-7	7 ± 1	SMFLDL-TTL-150	150 ± 4.5
SMFLDL-TTL-8	8 ± 1	SMFLDL-TTL-160	160 ± 4.5
SMFLDL-TTL-9	9 ± 1	SMFLDL-TTL-170	170 ± 5
SMFLDL-TTL-10	10 ± 1	SMFLDL-TTL-180	180 ± 5.5
SMFLDL-TTL-11	11 ± 1	SMFLDL-TTL-190	190 ± 6
SMFLDL-TTL-12	12 ± 1	SMFLDL-TTL-200	200 ± 6
SMFLDL-TTL-13	13 ± 1	SMFLDL-TTL-210	210 ± 6.5
SMFLDL-TTL-14	14 ± 1	SMFLDL-TTL-220	220 ± 7
SMFLDL-TTL-15	15 ± 1	SMFLDL-TTL-230	230 ± 7.5
SMFLDL-TTL-16	16 ± 1	SMFLDL-TTL-240	240 ± 8
SMFLDL-TTL-17	17 ± 1	SMFLDL-TTL-250	250 ± 8
SMFLDL-TTL-18	18 ± 1	SMFLDL-TTL-260	260 ± 8.5
SMFLDL-TTL-19	19 ± 1	SMFLDL-TTL-270	270 ± 9
SMFLDL-TTL-20	20 ± 1	SMFLDL-TTL-280	280 ± 9.5
SMFLDL-TTL-21	21 ± 1	SMFLDL-TTL-290	290 ± 10
SMFLDL-TTL-22	22 ± 1	SMFLDL-TTL-300	300 ± 10
SMFLDL-TTL-23	23 ± 1	SMFLDL-TTL-310	310 ± 10
SMFLDL-TTL-24	24 ± 1	SMFLDL-TTL-320	320 ± 11
SMFLDL-TTL-25	25 ± 1	SMFLDL-TTL-330	330 ± 11
SMFLDL-TTL-30	30 ± 1.5	SMFLDL-TTL-340	340 ± 11
SMFLDL-TTL-35	35 ± 1.5	SMFLDL-TTL-350	350 ± 11
SMFLDL-TTL-40	40 ± 1.5	SMFLDL-TTL-360	360 ± 11
SMFLDL-TTL-45	45 ± 2	SMFLDL-TTL-370	370 ± 12
SMFLDL-TTL-50	50 ± 2	SMFLDL-TTL-380	380 ± 12
SMFLDL-TTL-55	55 ± 2	SMFLDL-TTL-390	390 ± 12
SMFLDL-TTL-60	60 ± 2	SMFLDL-TTL-400	400 ± 12
SMFLDL-TTL-65	65 ± 2.5	SMFLDL-TTL-410	410 ± 13
SMFLDL-TTL-70	70 ± 2.5	SMFLDL-TTL-420	420 ± 13
SMFLDL-TTL-75	75 ± 2.5	SMFLDL-TTL-430	430 ± 13
SMFLDL-TTL-80	80 ± 2.5	SMFLDL-TTL-440	440 ± 14
SMFLDL-TTL-85	85 ± 3	SMFLDL-TTL-450	450 ± 14
SMFLDL-TTL-90	90 ± 3	SMFLDL-TTL-460	460 ± 14
SMFLDL-TTL-95	95 ± 3	SMFLDL-TTL-470	470 ± 15
SMFLDL-TTL-100	100 ± 3	SMFLDL-TTL-480	480 ± 15
SMFLDL-TTL-110	110 ± 3.5	SMFLDL-TTL-490	490 ± 15
SMFLDL-TTL-120	120 ± 4	SMFLDL-TTL-500	500 ± 15

∅ All modules can be operated with a minimum input pulse width of 100% of full delay and pulse period approaching square wave; since delay accuracies may be somewhat degraded, it is suggested that the module be evaluated under the intended specific operating conditions. **Special modules can be readily manufactured to improve accuracies and/or provide customer specified random delay times for specific applications.**

TEST CONDITIONS

- All measurements are made at 25°C.
- V_{CC} supply voltage is maintained at 5.0V DC.
- All units are tested using a FAST toggle-type positive input pulse and one FAST T²L load at the output.
- ∅ Input pulse width used is 100% longer than delay of module under test; spacing between pulses (falling edge to rising edge) is three times the pulse width used.