

## BLOCK DIAGRAM IS SHOWN BELOW

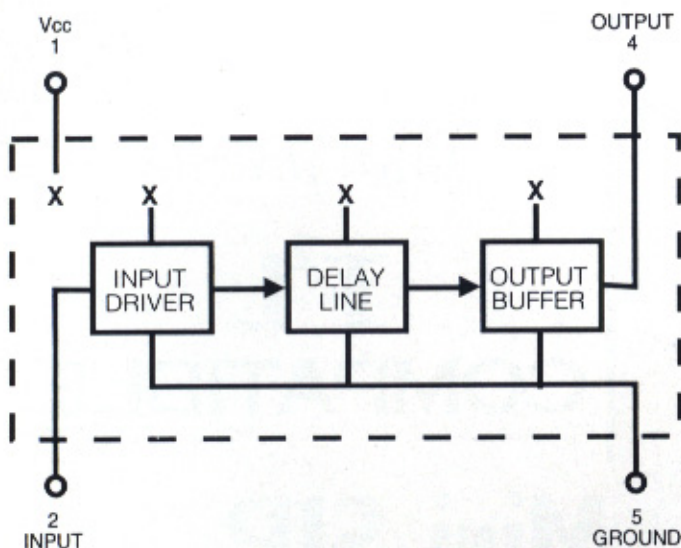

## MECHANICAL DETAIL IS SHOWN BELOW

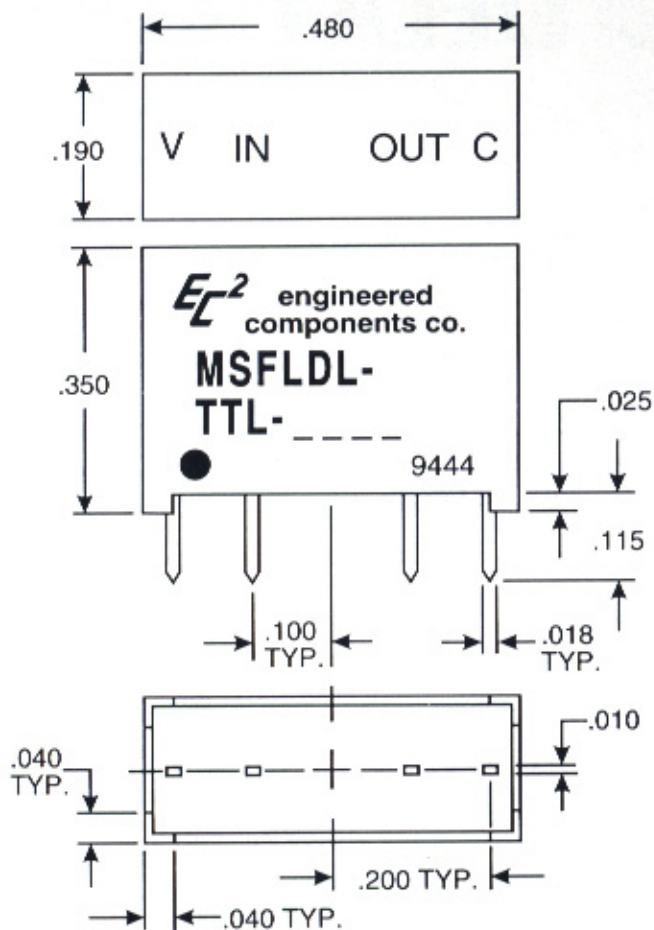

## TEST CONDITIONS

1. All measurements are made at 25°C.
2.  $V_{CC}$  supply voltage is maintained at 5.0V DC.
3. All units are tested using a FAST toggle-type positive input pulse and one FAST load at the output.
4. Input pulse width used is 100% longer than delay of module under test; spacing between pulses (falling edge to rising edge) is three times the pulse width used.

## OPERATING SPECIFICATIONS

- \*  $V_{CC}$  supply voltage: . . . . . 4.75 to 5.25V DC
- $V_{CC}$  supply current:
  - Constant "0" in . . . . . 60mA typical
  - Constant "1" in . . . . . 7mA typical
- Logic 1 Input:
  - Voltage . . . . . 2V min.;  $V_{CC}$  max.
  - Current . . . . . 2.7V = 20 $\mu$ A max.
  - 5.5V = 1mA max.
- Logic 0 Input:
  - Voltage . . . . . .8V max.
  - Current . . . . . -6mA max.
- Logic 1 Voltage out: . . . . . 2.7V min.
- Logic 0 Voltage out: . . . . . .5V max.
- Operating temperature range: . . . . . 0 to 70°C.
- Storage temperature: . . . . . -55 to +125°C.

\* Delays increase or decrease approximately 4% for a respective increase or decrease of 5% in supply voltage.

## PART NUMBER TABLE

DELAYS AND TOLERANCES (in ns)			
PART NUMBER	OUTPUT	PART NUMBER	OUTPUT
MSFLDL-TTL-5	5±1	MSFLDL-TTL-45	45±2
MSFLDL-TTL-6	6±1	MSFLDL-TTL-50	50±2
MSFLDL-TTL-7	7±1	MSFLDL-TTL-55	55±2
MSFLDL-TTL-8	8±1	MSFLDL-TTL-60	60±2
MSFLDL-TTL-9	9±1	MSFLDL-TTL-65	65±2.5
MSFLDL-TTL-10	10±1	MSFLDL-TTL-70	70±2.5
MSFLDL-TTL-11	11±1	MSFLDL-TTL-75	75±2.5
MSFLDL-TTL-12	12±1	MSFLDL-TTL-80	80±2.5
MSFLDL-TTL-13	13±1	MSFLDL-TTL-85	85±3
MSFLDL-TTL-14	14±1	MSFLDL-TTL-90	90±3
MSFLDL-TTL-15	15±1	MSFLDL-TTL-95	95±3
MSFLDL-TTL-16	16±1	MSFLDL-TTL-100	100±3
MSFLDL-TTL-17	17±1	MSFLDL-TTL-125	125±4
MSFLDL-TTL-18	18±1	MSFLDL-TTL-150	150±4.5
MSFLDL-TTL-19	19±1	MSFLDL-TTL-175	175±5
MSFLDL-TTL-20	20±1	MSFLDL-TTL-200	200±6
MSFLDL-TTL-21	21±1	MSFLDL-TTL-225	225±7
MSFLDL-TTL-22	22±1	MSFLDL-TTL-250	250±8
MSFLDL-TTL-23	23±1	MSFLDL-TTL-275	275±9
MSFLDL-TTL-24	24±1	MSFLDL-TTL-300	300±10
MSFLDL-TTL-25	25±1	MSFLDL-TTL-350	350±11
MSFLDL-TTL-30	30±1.5	MSFLDL-TTL-400	400±12
MSFLDL-TTL-35	35±1.5	MSFLDL-TTL-450	450±14
MSFLDL-TTL-40	40±1.5	MSFLDL-TTL-500	500±15

∅ All modules can be operated with a minimum input pulse width of 100% of full delay and pulse period approaching square wave; since delay accuracies may be somewhat degraded, it is suggested that the module be evaluated under the intended specific operating conditions. **Special modules can be readily manufactured to improve accuracies and/or provide customer specified delay times for specific applications.**