

BLOCK DIAGRAM IS SHOWN BELOW

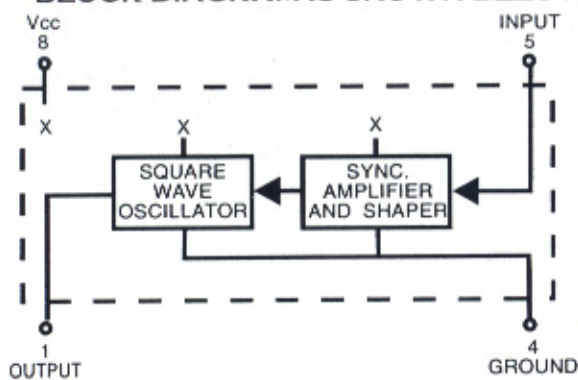

MECHANICAL DETAIL IS SHOWN BELOW

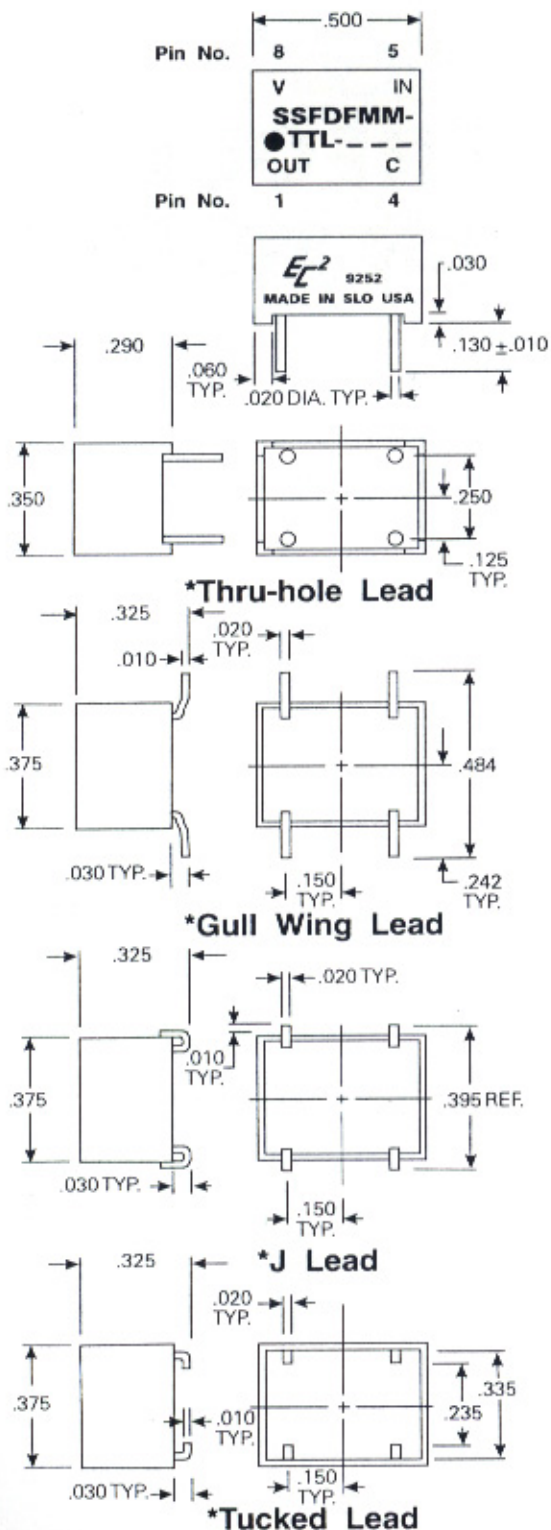

TEST CONDITIONS

1. All measurements are made at 25°C.
2. V_{cc} supply voltage is maintained at 5.0V DC.
3. All units are tested using a Schottky toggle-type input pulse and one Schottky T²L load at the output.
4. Input is T²L Schottky square wave at 20% of output frequency.

OPERATING SPECIFICATIONS

V_{cc} supply voltage: 4.75 to 5.25V DC
 V_{cc} supply current:
 SSFDFMM-TTL-2 30mA typical
 SSFDFMM-TTL-100 60mA typical
 (Current increases with operating frequency)

Logic 1 Input:
 Voltage 2V min.; V_{cc} max.
 Current 2.7V = 40uA max.
 @ max. V in = 200uA max

Logic 0 Input:
 Voltage8V max.
 Current -.4mA max.

Logic 1 Voltage out: 2.5V min.
 Logic 0 Voltage out:5V max.
 Operating temperature range: 0 to +70°C.
 Storage temperature: -55 to +125°C.

PART NUMBER TABLE

*Suffix Part Number with G (for Gull Wing Lead), J (for J Lead), F (for Thru-hole Lead) or T (for Tucked Lead). Examples: SSFDFMM-TTL-10G (Gull Wing), SSFDFMM-TTL-25J (J Lead), SSFDFMM-TTL-70F (Thru-hole Lead) or SSFDFMM-TTL-12T (Tucked Lead).

PART NUMBER	OUTPUT FREQUENCY	PART NUMBER	OUTPUT FREQUENCY
SSFDFMM-TTL-2	2 MHz	SSFDFMM-TTL-22	22 MHz
SSFDFMM-TTL-3	3 MHz	SSFDFMM-TTL-24	24 MHz
SSFDFMM-TTL-4	4 MHz	SSFDFMM-TTL-25	25 MHz
SSFDFMM-TTL-5	5 MHz	SSFDFMM-TTL-26	26 MHz
SSFDFMM-TTL-6	6 MHz	SSFDFMM-TTL-28	28 MHz
SSFDFMM-TTL-7	7 MHz	SSFDFMM-TTL-30	30 MHz
SSFDFMM-TTL-8	8 MHz	SSFDFMM-TTL-32	32 MHz
SSFDFMM-TTL-9	9 MHz	SSFDFMM-TTL-34	34 MHz
SSFDFMM-TTL-10	10 MHz	SSFDFMM-TTL-35	35 MHz
SSFDFMM-TTL-11	11 MHz	SSFDFMM-TTL-36	36 MHz
SSFDFMM-TTL-12	12 MHz	SSFDFMM-TTL-38	38 MHz
SSFDFMM-TTL-13	13 MHz	SSFDFMM-TTL-40	40 MHz
SSFDFMM-TTL-14	14 MHz	SSFDFMM-TTL-45	45 MHz
SSFDFMM-TTL-15	15 MHz	SSFDFMM-TTL-50	50 MHz
SSFDFMM-TTL-16	16 MHz	SSFDFMM-TTL-60	60 MHz
SSFDFMM-TTL-17	17 MHz	SSFDFMM-TTL-70	70 MHz
SSFDFMM-TTL-18	18 MHz	SSFDFMM-TTL-80	80 MHz
SSFDFMM-TTL-19	19 MHz	SSFDFMM-TTL-90	90 MHz
SSFDFMM-TTL-20	20 MHz	SSFDFMM-TTL-100	100 MHz

Special modules can be readily manufactured to provide customer specified output frequencies for specific applications.