

# EC<sup>2</sup>

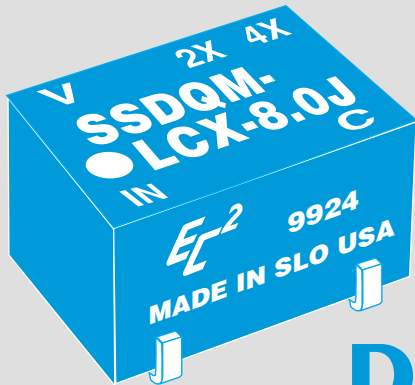

# space saver

## LCX 3V

# DIGITAL DOUBLER/ QUADRUPLER MODULE

- T<sup>2</sup>L LV CMOS input and outputs
- Output wavetrain are synchronized to input square wave
- 8-pin Space Saver package
- Available with input frequencies from 2.0 to 20 MHz
- 24mA output drive capability
- Leads - thru-hole, J, Gull Wing or Tucked
- Provides output at 2 and 4 times input frequency

the "Test Conditions" shown, the output frequencies will be exact multiples of the input. Each output on these modules is capable of driving  $\pm 24\text{mA}$ .

These SSDQM-LCX Digital Doubler/Quadrupler Modules are of hybrid construction utilizing the proven technologies of active integrated circuitry and of passive networks utilizing capacitive, inductive and resistive elements. The MTBF on these modules, when calculated per MIL-HDBK-217 for a 50°C ground fixed environment, is in excess of 3.7 million hours.

## design notes

The LCX "Space Saver Series" Digital Doubler/Quadrupler Modules developed by Engineered Components Company have been designed to provide precise 3V wavetrain outputs at two times (2X) and four times (4X) the input frequency. The input square-wave, typically from a crystal oscillator, is multiplied by the SSDQM-LCX module giving 2X and 4X outputs. Multiplication is accomplished by inserting timed edges and errors in this timing will result in jitter on the output waveforms. Timing edge jitter is less than 2% of the nominal input period. Variance of timing with temperature is less than  $\pm 600$  ppm/°C over the operating temperature range of -40 to +85°C.

The SSDQM-LCX is offered in twenty-five (25) standard clock input frequencies from 2.0 to 20.0 MHz. When tested under

The SSDQM-LCX "Space Saver Series" modules are packaged in an 8-pin housing, molded of flame-proof Diallyl Phthalate per MIL-M-14, Type SDG-F, and are fully encapsulated in epoxy resin. Thru-hole, J, Gull Wing or Tucked Lead configurations are available on these modules (see Part Number Table note to specify). Leads meet the solderability requirements of MIL-STD-202, Method 208. Corner stand-offs on the housing of the thru-hole version and lead design of the surface mount versions provide positive standoff from the printed circuit board to permit solder-fillet formation and flush cleaning of solder-flux residues for improved reliability.

Marking consists of manufacturer's name, logo (EC<sup>2</sup>), part number, terminal identification and date code of manufacture. All marking is applied by silk screen process using white epoxy paint in accordance with MIL-STD-130, to meet the permanency of identification required by MIL-STD-202, Method 215.

**EC<sup>2</sup> engineered components company**

P.O. Box 8121 • San Luis Obispo CA 93403-8121  
From California (805) 544-3800  
Toll Free (800) 235-4144  
FAX (805) 544-8091

www.ec2.com or  
www.engineeredcomponents.com  
info@ec2.com or  
info@engineeredcomponents.com

**BLOCK DIAGRAM IS SHOWN BELOW**

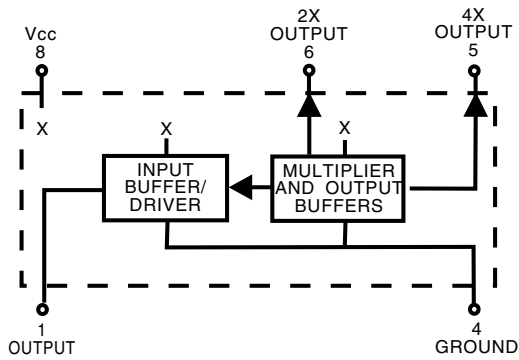

**MECHANICAL DETAIL IS SHOWN BELOW**

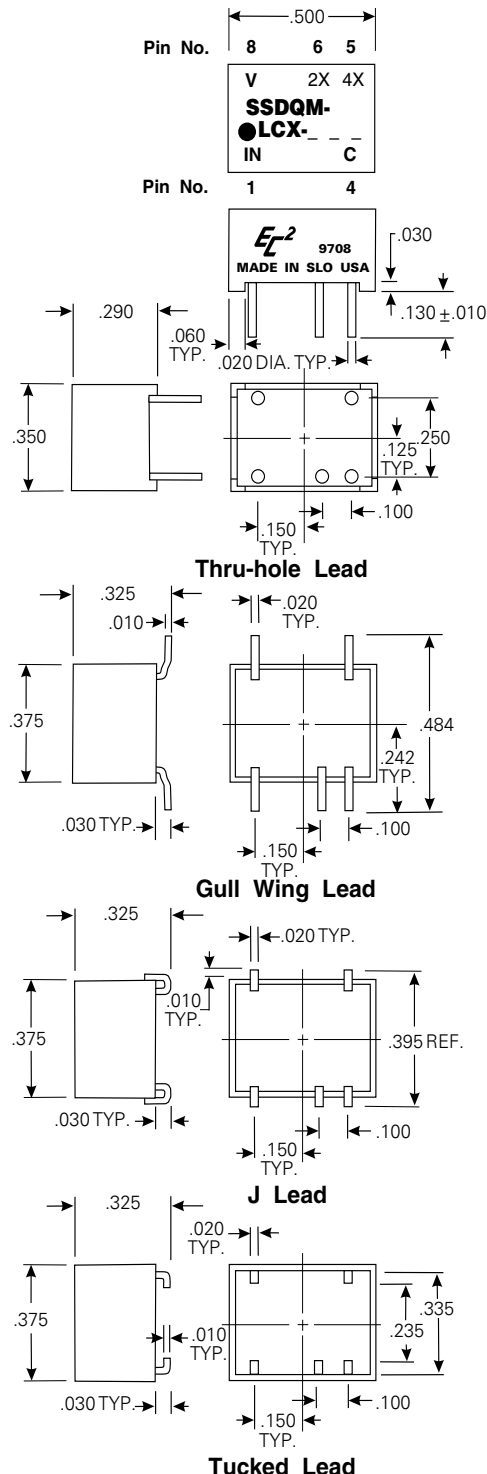

**TEST CONDITIONS**

1. All measurements are made at 25°C.
2. V<sub>CC</sub> supply voltage is maintained at 3.3V DC.
3. All units are tested using a LCX gate providing the input wavetrain and one LCX load at the output.
4. Input is a square wave at the module's nominal frequency.

**OPERATING SPECIFICATIONS**

V<sub>CC</sub> supply voltage: ----- 2.7 to 3.6V DC

V<sub>CC</sub> supply current: -----

SSDQM-LCX-2 ----- 14 mA typical

SSDQM-LCX-20 ----- 22 mA typical

(Current increases with operating frequency)

Logic 1 Input: -----

Voltage ----- 2.0V min.; 5.5V max.

Current ----- ±5µA max.

Logic 0 Input: -----

Voltage ----- .8V max.

Current ----- ±5µA max.

Logic 1 Voltage out: ----- 2.2V min.; V<sub>CC</sub> 3.0;

I<sub>OH</sub> -24mA

Logic 0 Voltage out: ----- .55V max.; V<sub>CC</sub> 3.0

I<sub>OL</sub> +24mA

Operating temperature range: ----- -40 to +85°C.

Storage temperature: ----- -55 to +125°C.

**PART NUMBER TABLE**

**Suffix Part Number with G (for Gull Wing Lead), J (for J Lead), F (for Thru-hole Lead) or T (for Tucked Lead). Examples: SSDQM-LCX-4.77G (Gull Wing), SSDQM-LCX-12J (J Lead), SSDQM-LCX-2.0F (Thru-hole Lead) or SSDQM-LCX-14.32T (Tucked Lead).**

PART NUMBER	INPUT FREQUENCY (MHz)	2X OUTPUT (MHz)	4X OUTPUT (MHz)
SSDQM-LCX-2.0	2.000	4.000	8.000
SSDQM-LCX-2.5	2.500	5.000	10.000
SSDQM-LCX-3.0	3.000	6.000	12.000
SSDQM-LCX-3.57	3.579	7.159	14.318
SSDQM-LCX-4.0	4.000	8.000	16.000
SSDQM-LCX-4.77	4.770	9.540	19.080
SSDQM-LCX-5.0	5.000	10.000	20.000
SSDQM-LCX-6.0	6.000	12.000	24.000
SSDQM-LCX-7.0	7.000	14.000	28.000
SSDQM-LCX-7.15	7.159	14.318	28.636
SSDQM-LCX-8.0	8.000	16.000	32.000
SSDQM-LCX-8.33	8.330	16.660	33.320
SSDQM-LCX-9.0	9.000	18.000	36.000
SSDQM-LCX-10	10.000	20.000	40.000
SSDQM-LCX-12	12.000	24.000	48.000
SSDQM-LCX-12.28	12.288	24.567	49.134
SSDQM-LCX-14.32	14.318	28.636	57.272
SSDQM-LCX-14.85	14.850	29.700	59.400
SSDQM-LCX-15	15.000	30.000	60.000
SSDQM-LCX-16	16.000	32.000	64.000
SSDQM-LCX-17	17.000	34.000	68.000
SSDQM-LCX-18	18.000	36.000	72.000
SSDQM-LCX-19	19.000	38.000	76.000
SSDQM-LCX-19.68	19.680	39.360	78.720
SSDQM-LCX-20	20.000	40.000	80.000

Special modules can be readily manufactured to provide customer specified input frequencies for specific applications.