

Hall-Effect Linear Current Sensor

The Hall-Effect Linear Current Sensors manufactured by Engineered Components Company provide a method for sensing the magnetic field associated with a current-carrying conductor, and providing an isolated analog output voltage that proportionally tracks a positive or negative input current. The Sensors can be operated with a supply voltage (V_{cc}) ranging between 5 and 10 volts DC.

With zero current applied, the output voltage is approximately equal to one-half of V_{cc} and is called the offset voltage. The output voltage increases with a positive input current, and decreases with a negative input current. The output voltage will track the input current waveform (I_c or DC) up to the peak current limits (see Figure 1). These linear current sensors are ratiometric, meaning that the characteristics vary in proportion to the supply voltage.

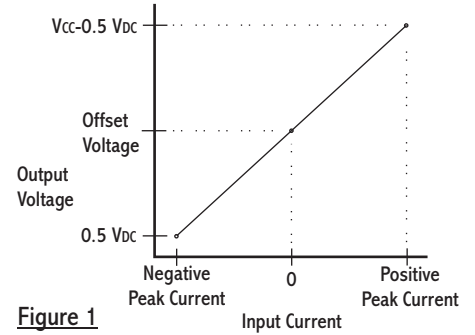

Figure 1

Product Selection Table

PART NUMBER	Peak Sensed Current (+/-A)	Sensitivity $V_{OUT}/Amps^*$	W	L	H	A
VHELCS-1	1.0	4.50V	.400	.900	.975	.034
VHELCS-3	3.0	1.50V	.400	.900	.975	.034
VHELCS-5	5.0	900mV	.400	.900	.975	.034
VHELCS-8	8.0	562mV	.500	.950	1.025	.054
VHELCS-10	10.0	450mV	.500	.950	1.025	.054
VHELCS-100	100 (SINGLE TURN)	45mV (SINGLE TURN)	.350	.900	.950	8-32 UNC-2A

* Sensitivity measured with $V_{cc} = +10.0$ Vdc.

Special modules can often be manufactured to provide for customer specific applications.

OPERATING SPECIFICATIONS

Operating Temp.....-40 to +125 C

Supply Voltage.....5.0 to 10 Vdc

Supply Current @5V.....7 mA typ.
8.5 mA max.

Offset Voltage.....($V_{cc}/2$) +/-3%

Offset Shift.....+/-0.06%/ C

Sensitivity Tolerance.....+/-10%

Output Linearity.....1% typ.

Frequency Response:

For $V_{cc} = 10$ Vdc....Flat to 20kHz

For $V_{cc} = 5$ Vdc....Flat to 10kHz

Input to Output isolation can
withstand 500 Vdc @ 50 uA

The current to be sensed is applied to the sensor coil leads marked with a "+" and a "-" on the front of the case. The VHELCS-100 is provided with two 8-32 thread brass mounting studs in place of the sensor coil leads. On this module, the customer can pass a current carrying wire through the center of the toroid core to function as a single turn coil. This single turn coil produces the peak currents shown for the VHELCS-100. Multiple turns can be passed through the center of the core to produce lower peak currents on this model. The three leads in the center of the module are the hall-effect sensor leads. A dot on the front of the case marks the output voltage lead. The center lead is the common lead and the far lead is the V_{cc} supply voltage lead (see Figure 2).

The Toroid and Sensor are secured in the housing with an epoxy resin. The housing material is a Liquid Crystal Polymer, off-white in color. Marking is applied by silkscreen using blue epoxy paint. Copper leads are lead-tin plated.

Front View

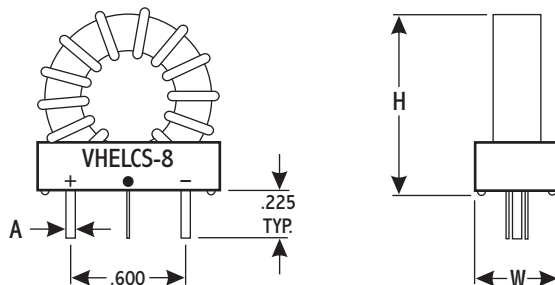

Back View

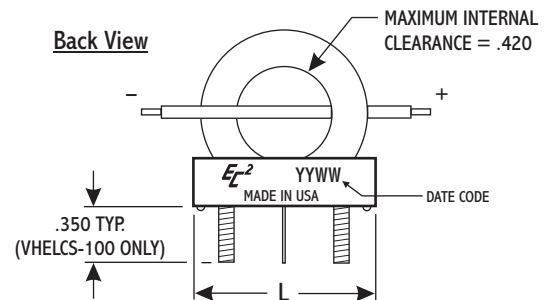

Bottom View

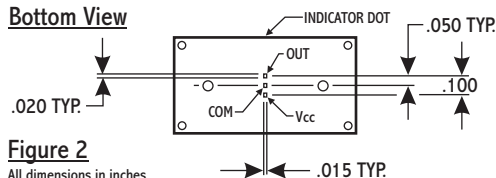

Figure 2

All dimensions in inches

NOTE: The front view drawing is showing the VHELCS-8 with the current sensing coil pre-wound on the toroid. The back view drawing is showing a VHELCS-100 with a single turn coil (supplied by the customer) passing through the center of the toroid.



engineered components company

A Division of Cornucopia Tool & Plastics, Inc. PO Box 1915, 448 Sherwood Rd., Paso Robles CA 93447

Phone: 805-369-0034

Fax: 805-369-0033

Web: www.ec2.com